

FIRST TEAM SPORTS, INC.

QuickSet Recreational Volleyball System

Assembly Instructions

FIGURE A

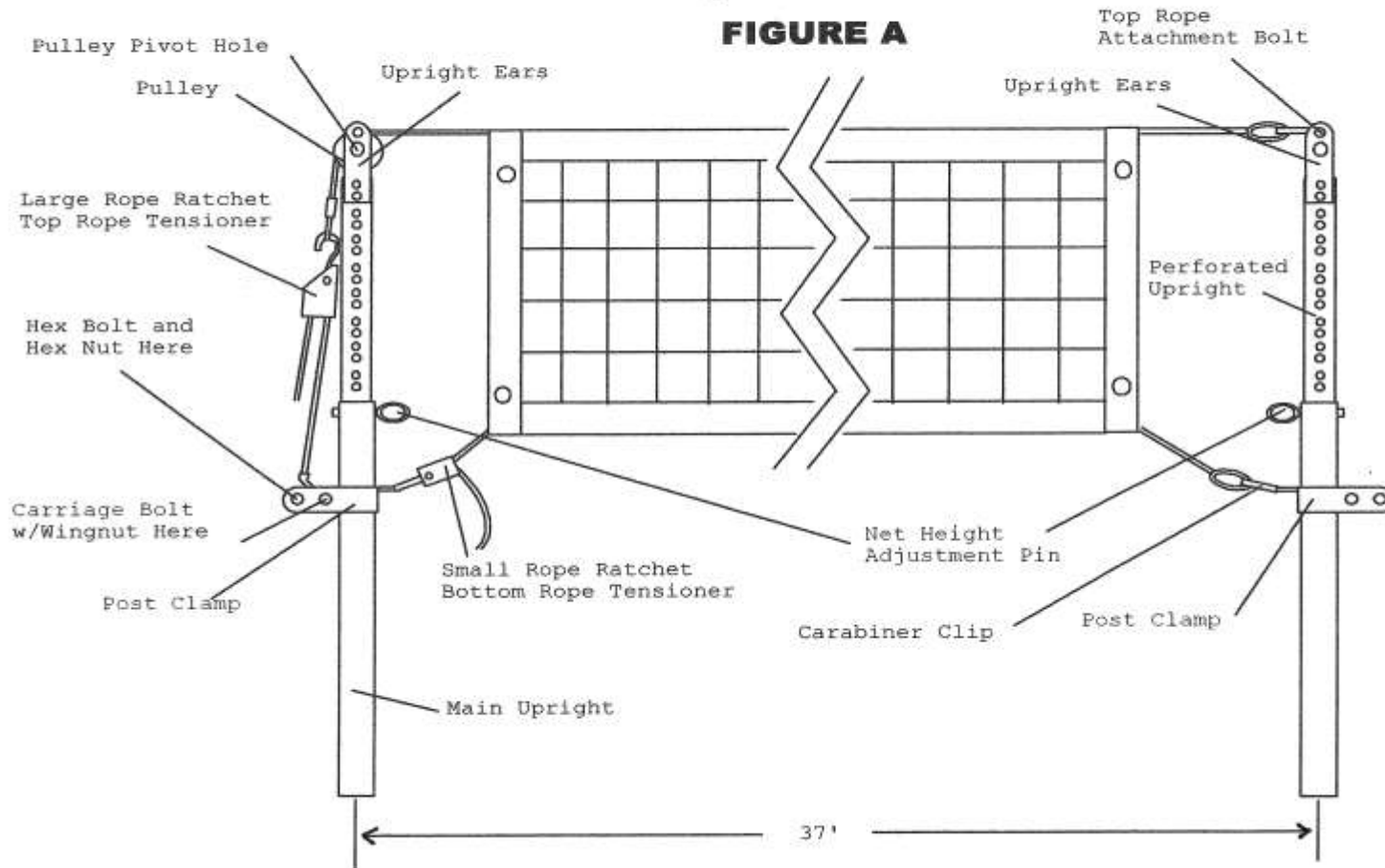

First Team Sports, Inc.

QUICKSET Recreational Volleyball System

BILL OF MATERIALS

A	2	Quickset Main Upright	J	2	3/8"x 2 3/4" Hex Bolt
B	2	Quickset Perforated Upright	K	2	3/8" x 2 3/4" Carriage Bolt
C	4	Upright Ear	L	5	3/8"x 2 1/2" Hex Bolt
D	2	Post Clamp	M	2	3/8" Wingnut
E	1	Pulley	N	7	3/8" Centerlock nut
F	1	Large Rope Ratchet	O	1	1/2"x 2 1/2" Hex Bolt
G	1	Small Rope Ratchet	P	1	1/2" Centerlock nut
H	2	Carabiner Clip	Q	2	3/8" x 2 1/2" Cotterless Pin
I	1	Volleyball Net	R	2	Pulley Spacer

NOTE: The above bill of materials applies to the volleyball system itself. Additional components may be included with your order such as upright padding, floor sockets, or ground stems. Bill of materials and installation instructions are included (if necessary) with any additional products provided with your order.

Inspect all contents prior to installation. Report any missing parts to First Team customer service immediately, 1-888-884-6677.

READ ALL INSTRUCTIONS BEFORE PROCEEDING!

-
1. Remove Volleyball Posts from packing.
 2. Locate and identify the "Main Posts" and "Perforated Uprights"
 3. Insert one end of the Perforated Upright approximately 18" into the end of the Main Post with the 3/8" hole drilled through it as shown in Figure A.
 4. Line up the holes in the Perforated Upright with the hole drilled through the Main Upright and secure using the 3/8" Cotterless Pin provided. (It does not matter which holes you pin the unit in for now)
 5. Repeat steps 3 and 4 for the other Main Upright and Perforated Upright trying your best to match the length of the first assembly.
 6. Using (4) 3/8"x 2 1/2" hex bolts and (4) 3/8" Centerlock nuts, bolt two Upright Ears to the top of each Perforated Upright. Be sure to bolt the ears to the two top 3/8" holes in the Perforated Upright as shown in Figure A.
 7. Next, secure the Pulley to the top of one of the Upright assemblies using (1) 1/2"x 2 1/2" Hex bolt and Centerlock nut. (2) Pulley Spacers are included. Use

these spacers to keep pulley “centered” between the upright ears. You will place (1) spacer on either side of the pulley.

8. On the opposite Upright pass (1) 3/8” x 2 1/2” hex bolt through the topmost hole in the Upright Ears and secure it in place using a 3/8” Centerlock nut. DO NOT OVERTIGHTEN!
9. Next, slide (1) Post Clamp onto each Upright as shown in Figure A. Secure each Post Clamp to Upright using (1) 3/8” x 2 3/4” Carriage Bolt and 3/8” Wingnut in the hole shown in Figure A. Tighten Wingnut until Post Clamp is tight enough that it will not move.
10. Then, ON THE POST WITH THE PULLEY, attach (1) 3/8” x 2 3/4” Hex Bolt and (1) 3/8” Centerlock nut to the holes furthest out on the Post Clamp.

AT THIS POINT – You must determine what type of ground attachment parts you purchased with your QUICKSET unit. The two types of ground attachment packages are listed below.

QuickSet-PM – Comes with ground stem attachments that can be cemented into the ground for a permanent QuickSet installation. (requires drilling)

QuickSet-NP – Same as QuickSet-PM excluding post pads

QuickSet-SP – Includes same ground stem attachments as QuickSet-PM, but also includes our Floor Sockets which can be installed indoors or outdoors that allow removal and storage when QuickSet is not in use.

Follow the installation instructions pertaining to your ground attachments from this point forward.

QuickSet-PM

Unpack your QuickSet ground anchors.

Using the Volleyball Diagram provided, determine where each Upright is to be located. Remember, each post should be approximately 37’ apart.

Once, you have your Upright locations marked. Dig a hole approximately 12” in diameter x 30” deep.

Fill each hole with wet concrete and submerge each ground anchor into the wet concrete until both round discs are covered with concrete leaving the square tubing exposed ABOVE concrete level. BE CERTAIN THE GROUND ANCHORS ARE SQUARE TO EACH OTHER AND SQUARE TO THE PLAYING COURT! See Figure C. Ground Stems MUST be PLUMB and SQUARE!!

STOP!! STOP!! STOP!! - Allow concrete to cure for 7 days.

After concrete has cured for full 7 days, slide each Upright down over top of each Ground Anchor with Post Clamps facing AWAY from playing court as shown in Figure A.

TIP: You may choose to drill through Uprights/Ground Anchors and bolt them together to prevent unwanted Upright removal.

FROM HERE JUMP TO – “NET ATTACHMENT”

QuickSet – SP

Your QuickSet system came with two Ground/Floor Sockets with hinged chrome lids. Unpack these Floor sockets and follow the installation instructions that pertain to your particular application.

After the concrete has cured. Open the lid of each Floor Socket and insert one Ground Anchor into each Socket. (square tubing should extend up out the top of the Socket)

Slide each Upright down over top of each Ground Anchor with Post Clamps facing AWAY from playing court as shown in Figure A.

FROM HERE JUMP TO – “NET ATTACHMENT”

NET ATTACHMENT

11. Unpack Volleyball Net. Lay net out flat on the floor. Notice that the ropes are different lengths. The TOP of the net is the side with the SHORTER rope, called the TOP ROPE. Your TOP ROPE should have a loop at each end. The BOTTOM ROPE should be longer than the top and should have only one loop. Slide dowels into side tape pouches.
12. Attach (2) Carabiner Clips to the end of the net that has a loop at the top and at the bottom.
13. Next, using the Carabiner Clip, attach the TOP ROPE to the TOP ROPE ATTACHMENT BOLT at the top of the Post as shown in Figure A.
14. Drape the other end of the TOP ROPE over the Net Pulley at the top of the other post.
15. Next, remove the Net Height Adjustment Pin on each Upright and telescope up or down to the approximate desired playing height. Replace pins.
16. Slide each Post Clamp to a height approximately 3” below bottom of net and clamp tight with Wingnut.

17. Connect TOP ROPE to outermost bolt on Post Clamp using the LARGE rope ratchet as shown in Figure A. (You may need to attach provided "S" hook to one end of the rope. Follow instructions on rope ratchet casing to feed rope through rope ratchet.)
18. Attach looped end of the BOTTOM ROPE to the opposite Post Clamp using a Carabiner Clip.
19. Locate the Small Rope Tensioner. Thread BOTTOM ROPE through Rope Tensioner as indicated on the tensioner's plastic casing, or see Figure B.
20. Connect SMALL rope tensioner to the bent tab on the Post Clamp as shown in Figure A.
21. Tension TOP ROPE by tensioning the LARGE ROPE RATCHET. When tension is sufficient, tighten the SMALL ROPE RATCHET as well. NOTE: The SMALL rope ratchet need NOT be tensioned to the same degree as the LARGE. (About $\frac{1}{2}$ - $\frac{3}{4}$ tension is adequate)
22. Attach Padding to Uprights if applicable.

QuickSet Volleyball Systems
Assembly Instructions

FIGURE B

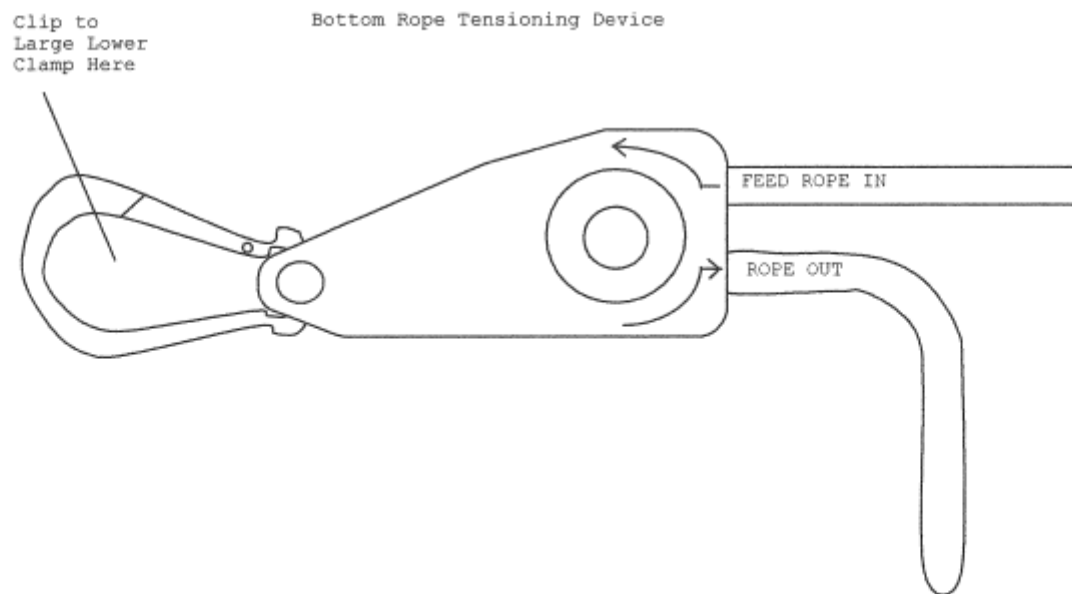

QUICKSET FIGURE C

(For QUICKSET-PM Packages Only)

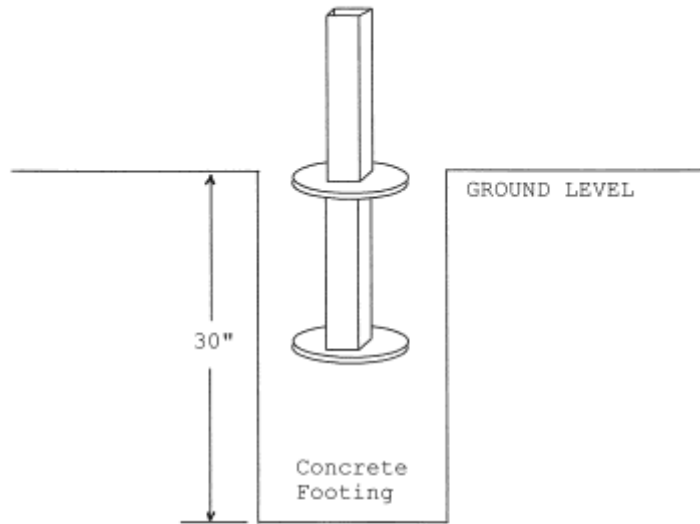

Volleyball Court Diagram

