

FIRST TEAM, INC. - WALLMONSTER SERIES

Installation Instructions

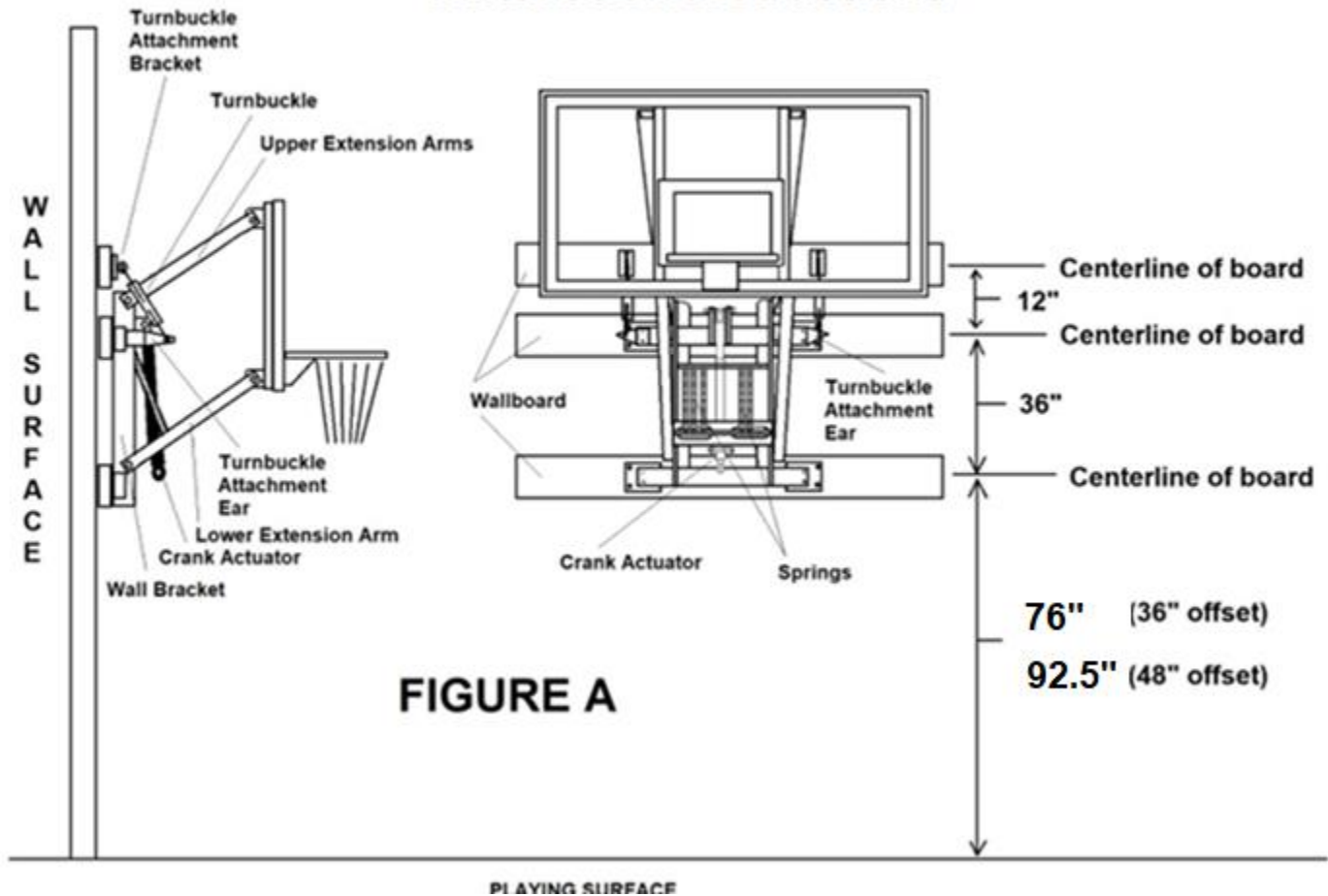

Bill of Materials

- | | |
|-------------------------------------|-----------------------------------|
| (1) Wall Bracket | (1) 5/8" x 5" Hex Bolt |
| (2) Upper Extension Arm | (10) 5/8" Center Lock Nut |
| (1) Lower Extension Arm Assembly | (8) 5/8" Nylon Flat Washer |
| (1) H-Frame Backboard Mount | (2) Turnbuckle |
| (12) 3/8"x 2 1/2" Fanged Elev. Bolt | (12) 3/8" x 1 1/4" Hex Bolt |
| (1) Rim Height Indicator | (24) 3/8" Flat Washer |
| (1) Adjustment Crank Actuator | (24) 3/8" Lock Washer |
| (1) Crank Handle | (24) 3/8" Hex Nut |
| (5) Lift Spring | (2) Turnbuckle Attachment Bracket |
| (1) Rim Height Stickers | (2) Turnbuckle Attachment Ear |
| (8) 5/8" x 3" Hex Bolt | (1) Set of three Wallboard |
| (1) 5/8" x 4 1/2" Hex Bolt | |

NOTE: Immediately unpack all components and cross check against bill of materials. Report any shortages to First Team customer service at 1-888-884-6677.

WARNING!! WARNING!! WARNING!! WARNING!! WARNING!!

Wall mount structures require a minimum ceiling and wall height as well as an acceptable wall mounting surface. Solid Block, or Poured Concrete walls are superior. It is inadvisable to mount structures to walls with wood or steel studs unless additional work approved by an engineer is done to provide additional support. First Team does not provide wall anchors with any structure. The purchaser assumes liability for the installation of any wall mounting structure. Consult a professional architect, engineer, or contractor to determine safe methods of installation to your facility's wall construction. SEVERE INJURY OR DEATH MAY OCCUR IF UNIT IS INSTALLED IMPROPERLY OR INSTALLED ON A WALL THAT IS INADEQUATE TO SUPPORT THE WEIGHT OF THE UNIT AND ANY ADDED WEIGHT FROM PLAYER(S) HANGING ON THE STRUCTURE.

WARNING!! WARNING!! WARNING!! WARNING!! WARNING!!

All assembly materials are supplied except hardware to attach the wallboards to the customer's wall. Attachment method and type of anchor used are the responsibility of the installer. SEVERE INJURY OR DEATH MAY RESULT FROM FAILURE TO SELECT A PROPER ANCHORING SYSTEM GIVEN THE CONSTRUCTION & CONDITION OF THE WALL OR IMPROPER USE OF THE PROPER ANCHORING SYSTEM!!

Read and understand all instructions completely before proceeding with installation.

WALLMONSTER WALL MOUNTING

Unpack all three WALLBOARDS from their packaging. Insert (4) Fanged Elevator bolts into the (4) centermost predrilled holes in each of the three WALLBOARDS. Insert the Fanged Elevator bolts from the back side of each board with bolt threads protruding through the WALLBOARDS so they will be pointing toward the basketball court when WALLBOARD is mounted on the wall. Disregard the additional predrilled holes, they are for use with installing other First Team products. Make sure the "fangs" of the ELEVATOR BOLTS are biting into the back side of the WALLBOARD. Pound them into place with a hammer as needed.

Refer to FIGURE A on page one of the assembly instructions. NOTE: The WallMonster may be installed either with a 36" or 48" OFFSET (distance from wall to backboard with rim at ten feet) Position the lowest WALLBOARD on the wall based on your choice of either a 36" or 48" offset using FIGURE A as a reference for the proper starting dimension. Be sure WALLBOARD is positioned correct distance above playing surface. NOTE: The dimensions given are to the CENTERLINE of the WALLBOARD. Secure the WALLBOARD to wall.

HARDWARE FOR SECURING WALLBOARD TO WALL IS NOT SUPPLIED AND IS THE RESPONSIBILITY OF THE CUSTOMER. Secure WALLBOARD to wall in a minimum for 4 places. REMEMBER: You will need to drill your own holes in the WALLBOARD for attachment to wall. The additional pre-drilled holes are NOT intended to be used as a guide

for wall attachment locations. Repeat the above step for the other two WALLBOARDS using FIGURE A as a guide for locating the other two WALLBOARDS.

Position the WALL BRACKET onto the lower and middle WALLBOARDS lining up the 3/8" Fanged Elevator Bolts with the corresponding holes in the WALL BRACKET. NOTE: Be sure to install the WALL BRACKET right side up. The end with the 5/8" round rod welded across should be installed UP. Secure the WALL BRACKET to wallboards using (8) 3/8" flat washers, (8) 3/8" lock washers and (8) 3/8" hex nuts provided. While securing WALL BRACKET to wall it is important to place a level on the side of the WALL BRACKET to ensure that the structure is level side to side before finishing attachment. Adjust as necessary until level and tighten 3/8" hex nuts.

NOTE: After you are satisfied that the structure is adequately fastened to the wall and that the wall is adequate to support the weight of this basketball system, you may proceed with the rest of the installation.

Next, attach (2) TURNBUCKLE BRACKETS to the top WALLBOARD using (4) 3/8" flat washers, (4) 3/8" lock washers and (4) 3/8" hex nuts.

Attach (2) TURNBUCKLE ATTACHMENT EAR (these parts are triangular shaped) to the holes provided at the top of the WALL BRACKET using (4) 3/8" x 1 1/4" Hex Bolts, (4) 3/8" Flat Washers, (4) 3/8" Lock Washers and (4) 3/8" Hex Nuts. (reference Figure A)

Two TURNBUCKLES are provided. Adjust the length of both TURNBUCKLES until they are the correct length to reach from the TURNBUCKLE ATTACHMENT BRACKET on the top WALLBOARD down to the TURNBUCKLE ATTACHMENT EAR at the top of the WALL BRACKET. Connect both TURNBUCKLES using the pins & hardware provided in the TURNBUCKLES. Once attached, twist both TURNBUCKLES until they are SNUG, DO NOT OVERTIGHTEN THE TURNBUCKLES!!!

Locate the LOWER EXTENSION ARM ASSEMBLY. Note that the LOWER EXTENSION ARM has a channel bracket with a 5/8" rod welded inside it. The LOWER EXTENSION ARM will be bolted to the WALL BRACKET with the face of the channel UP and the legs of the channel pointing DOWN. Additionally, the LOWER EXTENSION ARM will be attached to the WALL BRACKET at the end closest to the channel. With the LOWER EXTENSION ARM assembly oriented properly, attach the LOWER EXTENSION ARM to the WALL BRACKET using (2) 5/8" x 3" Hex Bolt, (2) 5/8" Nylon Flat Washer and (2) 5/8" Center Lock Nut. Place one nylon flat washer on each side between the LOWER EXTENSION ARM ASSEMBLY and the WALL BRACKET SUPPORT. The nylon flat washers eliminate paint wear and provide free movement at the pivot points. Remember, the nylon flat washers go BETWEEN the extension arms and the side of the wall bracket.

Attach the UPPER EXTENSION ARMS using (2) 5/8" x 3" Hex Bolt, (2) 5/8" Nylon Flat Washer and (2) 5/8" Center Lock Nut. Remember the nylon flat washers go BETWEEN the extension arms and the side of the wall bracket.

Next, using (1) 5/8" x 4 1/2" Hex Bolt and (1) 5/8" Center Lock Nut, attach the ADJUSTMENT CRANK ACTUATOR to the ACTUATOR ATTACHMENT EARS on the WALL BRACKET (see Figure D). The yoked clevis of the ADJUSTMENT CRANK ACTUATOR should be cradled between the two welded tabs (ACTUATOR ATTACHMENT EARS) at the top of the WALL BRACKET support. Also attach the RIM HEIGHT INDICATOR at this time. The welded tube on the RIM HEIGHT INDICATOR fits between the yoked clevis on the ADJUSTMENT CRANK ACTUATOR. NOTE OF CLARIFICATION: The ADJUSTMENT CRANK ACTUATOR and RIM HEIGHT INDICATOR are both attached using the same 5/8"x 4 1/2" Hex Bolt mentioned above.

Using (1) 5/8" x 5" Hex Bolt provided and (1) 5/8" Center Lock Nut attach the bottom end of the ADJUSTMENT CRANK ACTUATOR between the set of welded ears on the LOWER EXTENSION ARM as shown in Figure A. Position the ADJUSTMENT CRANK ACTUATOR so the round mounting tube the bolt passes through is facing the basketball court and the body of the ACTUATOR is closest to the wall.

Bolt the H-FRAME BACKBOARD MOUNT to the LOWER & UPPER EXTENSION ARMS using (4) 5/8"x3" Hex Bolt, (4) 5/8" Nylon Flat Washer and (4) 5/8" Center Lock Nut. Remember to place the nylon flat washers between the extension arms and the sides of the H-FRAME BACKBOARD MOUNT.

IF YOU PURCHASED A TEMPERED GLASS OR ACRYLIC (plexiglass) BACKBOARD you should find (4) grommets mounted in the four rim holes in the glass/acrylic. If the grommets are not there, check in the box, they may have fallen out during shipping. If the grommets are missing and cannot be located, DO NOT PROCEED WITH INSTALLATION, call First Team immediately for replacements, 1-888-884-6677. Grommets prevent glass/acrylic breakage when tightening rim bolts. NO GROMMETS ARE NECESSARY FOR NON-CLEAR BACKBOARDS.

Hang BACKBOARD on H-FRAME lining up the four holes at the top of the BACKBOARD frame with the four holes in the top of the H-FRAME.

Loosely attach BACKBOARD at these four points using (4) 3/8" x 1 1/4" Hex Bolt, (4) 3/8" Flat Washer, (4) 3/8" Lock Washer & (4) 3/8" Hex Nut provided.

Loosely attach BACKBOARD to H-FRAME at the four points along the bottom of the BACKBOARD frame as well. Use (4) 3/8" x 1 1/4" Hex Bolt, (4) 3/8" Flat Washer, (4) 3/8" Lock Washer & (4) 3/8" Hex Nut provided. Be sure the rim holes in the BACKBOARD and the rim

holes in the H-FRAME are aligned so the rim bolts will be able to pass thru when attaching RIM. When satisfied with hole alignment, tighten the 3/8" hardware at both the top and bottom of the BACKBOARD frame.

If you have a tempered glass or acrylic backboard, check once again to make sure all (4) grommets are in place in the backboard rim mounting holes. When you are satisfied with rim hole/H-FRAME alignment, attach RIM following the instructions provided in the RIM box.

Next, using a tape measure and CRANK HANDLE, crank the unit upward so RIM reaches as high as possible. Then attach (3) LIFT SPRINGS on one side of the CRANK ADJUSTMENT ACTUATOR and (2) LIFT SPRINGS on the other side of the CRANK ADJUSTMENT ACTUATOR. It does not matter which side has three springs and which side has two. Attach one end first on the LIFT SPRING ATTACHMENT ROD welded on the WALL BRACKET (see Figure C) and the other end of the LIFT SPRING on the 5/8" ROD welded into the mounting channel on the LOWER EXTENSION ARM. (see Figure A)

Next, using a measuring tape and CRANK HANDLE, crank unit until RIM measures 10' above playing surface. Make a pencil mark on the side of the ADJUSTMENT CRANK ACTUATOR where the RIM HEIGHT INDICATOR stops. Repeat this step for 9 ½', 9', 8 ½', 8', 7 ½'. When finished peel and apply each RIM HEIGHT STICKER lining up the pencil mark with the mark provided on each respective sticker.

Make sure all hardware has been tightened. If unit is difficult to crank you may have over tightened the bolts at the main pivot points, try loosening them slightly. Check over the unit periodically to make sure no hardware has loosened as the unit ages.

Installation of your First Team WallMonster Basketball System is complete!

TIP: Find a safe and handy location to store your crank handle. If you ever lose your crank handle, replacements can be purchased by calling First Team at 1-888-884-6677. We hope you enjoy your WallMonster basketball system.

DIAGRAM OF PARTS

(NOTE: WALL BRACKET SHOWN IN FIGURES C&D)

Upper Extension
Arm

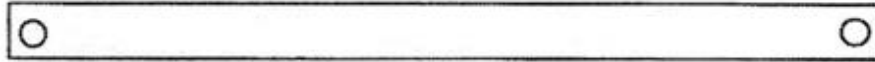

Lower Extension
Arm

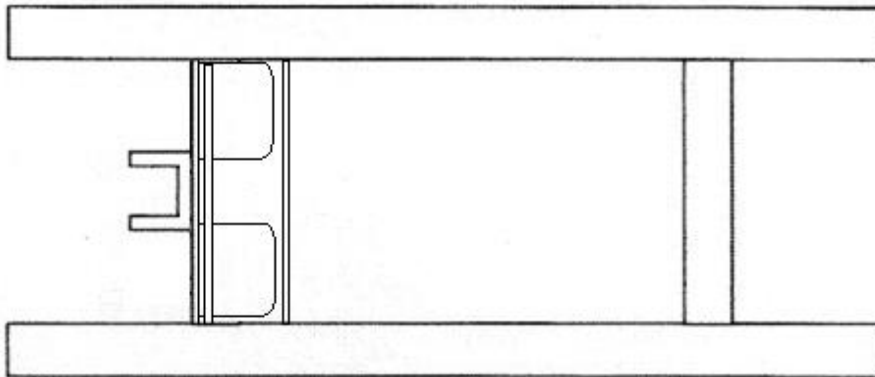

H-Frame

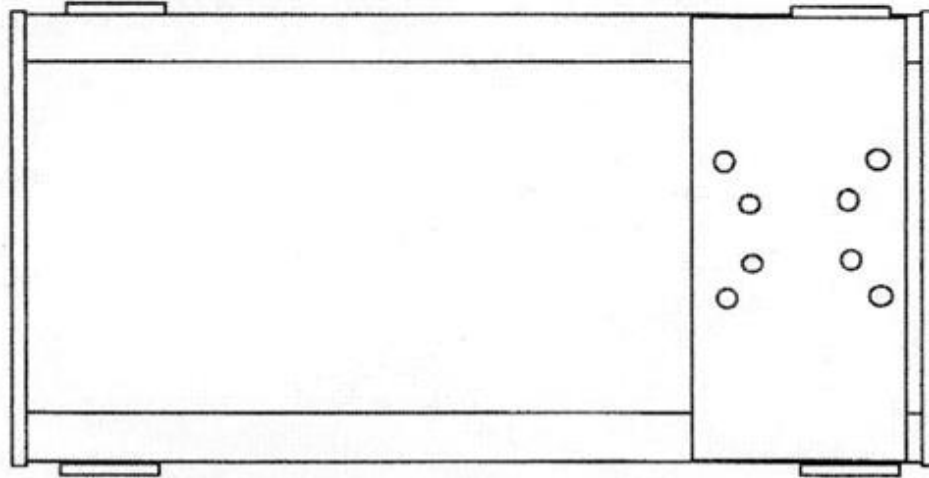

Rim Height
Indicator

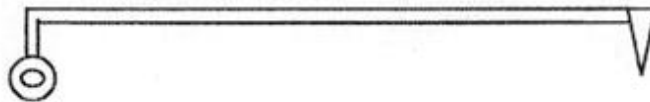

Adjustment
Crank

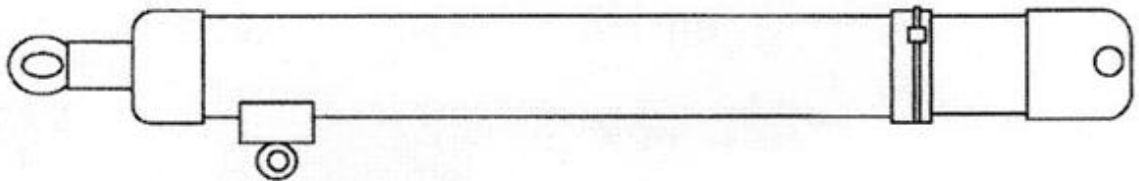

Crank Handle



FIGURE C
WALL BRACKET FRONT VIEW

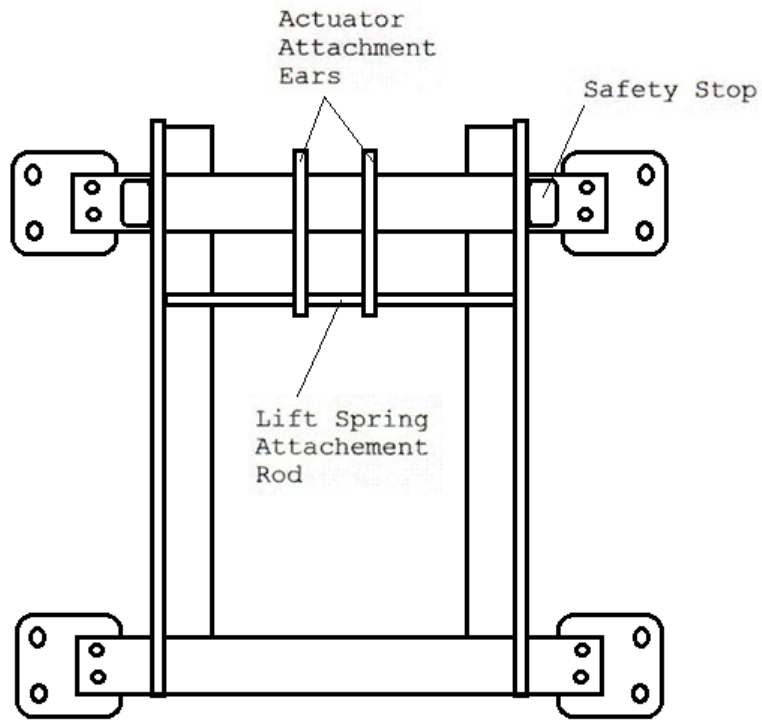

FIGURE D
WALL BRACKET SIDE VIEW

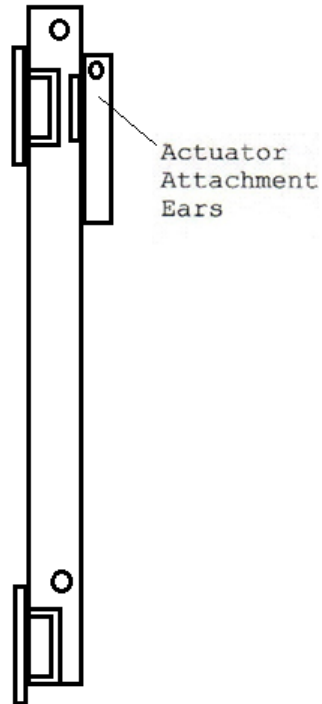

FIGURE E
ACTUATOR

